

Create a Brighter Future for Students on Your Campus



Joe is a native Georgian, employed by Van Meter since 2006. He is responsible for lighting and control design for Eastern Iowa including Davenport, Muscatine, Burlington, and Keokuk. Joe is also technical resource for customers and offers onsite training and product/technology updates. Member of the IESNA since 2007 with 19 years total experience in the Electrical Distribution field and 12 years experience in lighting.



Todd has been with Van Meter since March of 2003 as the Lighting Specialist for West Central Iowa. He works closely with electrical contractors, architects, and specifiers on design/build projects, as well as lighting energy audits. Prior to coming to Van Meter, he worked for CED-Des Moines as an Inside Salesperson and before that worked for a high-voltage electrical equipment manufacturers representative agency in Kansas and Missouri calling on REC's, Municipalities, and investor owned Utilities. Todd is a graduate of the University of Iowa with a B.A. in Communications.



Bob Workman, a Lighting Specialist for Van Meter Inc., has been in the industry for more than four years. His responsibilities include lighting design, sales and education and lighting and energy audits. He gives consultation to commercial, institutional, industrial and contractor businesses and works to support his fellow Van Meter sales people covering East Central Iowa including Cedar Rapids, Iowa City, Waterloo, Dubuque and Mason City.

Create a Brighter Future for Students on Your Campus

Joe Bryan, Todd Tiernan and Bob
Workman

Van Meter Lighting Specialists

Sustainability

- Sustainability is defined as meeting the needs of the present generation without compromising the ability of future generations to meet their own needs.

How Does Lighting Impact the Environment

- Green House Gas Emissions from Electricity consumption.
- Toxicity from Mercury and other Hazardous material.
- Material Consumption and Disposal.

Sustainable Lighting

How do we reduce the Environmental Impact?

- More Energy Efficient Lighting Systems
- Lower or no Mercury.
- Long Lamp Life/Recycling.

Which Technologies are Sustainable?

- Obsolete/Not Sustainable
 - Probe Start Metal Halide
 - T12 Magnetic Fluorescent
 - Incandescent/Halogen
- Not Obsolete/Better
 - -Standard T8/T5 Fluorescent- Standard Fixtures
 - Pulse Start Metal Halide
 - High Pressure Sodium
 - Higher Efficiency Halogen
 - Screw in CFL's

Which Technologies are Sustainable?

- Sustainable Lighting

- High Efficiency/Long Life/Low Mercury T8 and T5 in High Efficiency Fixtures.
- High Efficiency HID
- Induction Lighting
- High Quality LED
- Lighting Controls

Light Source	Lumens/Watt	Lamp Life (hrs)	Mercury Content
Probe Start Metal Halide	40-70	10,000-20,000	20mg+
T12 Fluorescent	50-70	20,000	20mg+
Incandescent and Halogen	15-40	1,000-5,000	0
Pulse Start Metal Halide	60-90	20,000	20mg+
Standard T8/T5	70-100	30,000-35,000	1.7mg(philips) 3+(the rest)
High Efficiency Halogen	30-50	2500-5000	0
Compact Fluorescent	50-80	8,000-20,000	2mg-15mg
High Efficiency Long Life T8/T5	90-120	Up to 46,000	1.7mg(philips) 3+(the rest)
High Efficiency Metal Halide	90-120	Up to 30,000	20mg+
Induction Lighting	80-100	100,000	5mg-10mg
LED	50-90	25,000-100,000	0

Inefficient Fluorescent Fixtures



Efficient Fluorescent Fixtures



LED Fixtures



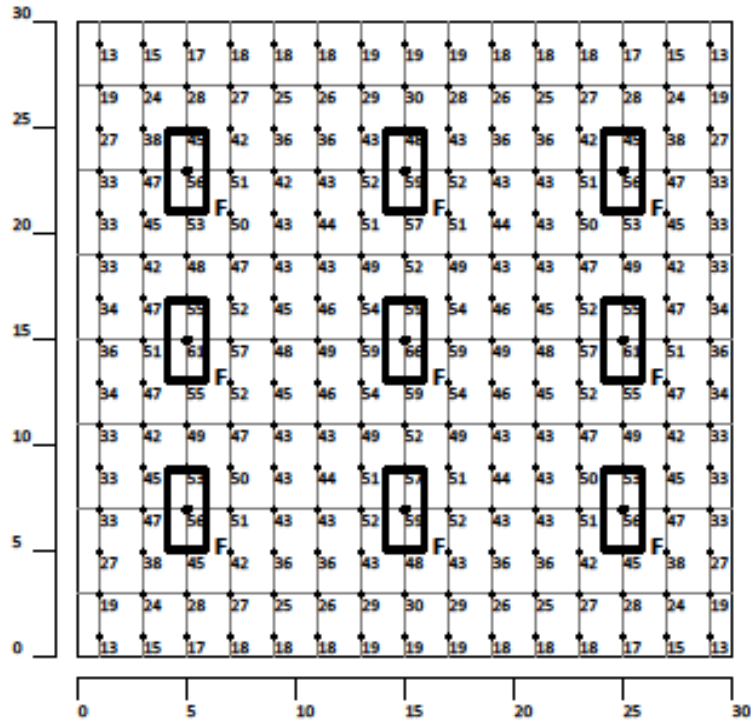

Initial Illumination at +30° AFF
Scale: 1 inch= 8 Ft.

Luminaire Schedule									
Symbol	Qty	Label	Description	No. Lamps	Lumens/Lamp	lum. Lumens	LLF	Lum. Watts	
F1	6	F1	Lithonia ZRT185 2'x2'	2	2800	4516	0.88	54.8	

Numeric Summary								
Label	CalcType	Units	Avg	Max	Min	Avg/Min	Max/Min	
Layout1	Workplane 1	Illuminance	Fc	39.19	66	13	3.01	5.08

Room Summary			
Label	Type	Wall Ht.	Description
Layout1	Rect-Flat	8	30'x30'x8' H Room, rct. 80/50/20



ROOM: 30' x 30'

Page 1 of 1

Date:6/3/2011

By:

Rev:

CREE 
LED Lighting

505 LUIS LUIVA, SUITE 100, MOTTENHAWK, NJ 07050

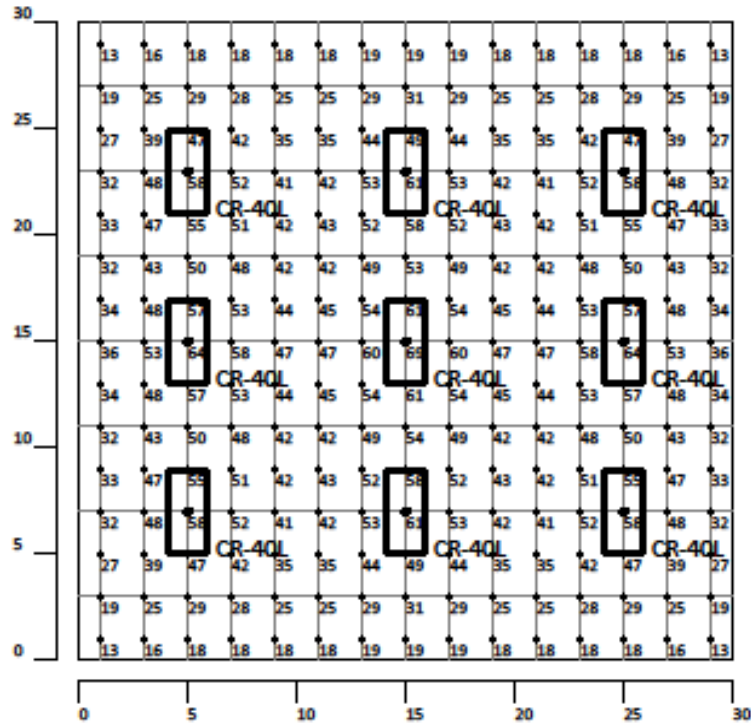

Initial Illumination at +30° AFF
Scale: 1 inch= 8 Ft.

Luminaire Schedule								
Symbol	Qty	Label	Description	No. Lamps	Lumens/Lamp	Lum. Lumens	LLF	Lum. Watts
-	9	CR-40L	Cree CR24-40L	1	4000	4000	1.00	44

Numeric Summary								
Label	Calc/Type	Units	Avg	Max	Min	Avg/Min	Max/Min	
Layout1	Workplane 1	Illuminance	Fc	39.56	69	13	3.04	5.31

Room Summary			
Label	Type	Wall Ht.	Description
Layout1	Rect-Flat	8	30'x30'x8' H Room, r0L80'50'20



ROOM: 30' x 30'

By: MCZ

Date:6/3/2011

Rev:

CREE
LED Lighting

505 LIGUIS LANE, SUITE 100, MORRISVILLE, NC 27560

Philips Lighting, making the future brighter.

Standard Philips Incandescent A19	EcoVantage A-Shape	Energy Saver CFL Twister	EnduraLED A-Shape
Watts	60W	43W	13W
Rated Average Life ¹	1000	1000	10,000
Brightness/Lumens	860	800	900
Potential Energy Savings ²	—	Potential Energy Savings² \$1.87	Potential Energy Savings² \$47.00
Watts	12.5W	800	12.5W
Rated Average Life ¹	25,000	800	25,000
Brightness/Lumens	800	800	800
Potential Energy Savings ²	—	Potential Energy Savings² \$130.63	

Standard Philips Incandescent R20	Halogen Energy Advantage R20	Energy Saver CFL R20	EnduraLED PAR20
Watts	50W	40W	14W
Rated Average Life ¹	2000	3000	8000
Brightness/Lumens	380	550	500
Potential Energy Savings ²	—	Potential Energy Savings² \$3.30	Potential Energy Savings² \$28.80
Watts	7W	45,000	600
Rated Average Life ¹	45,000	600	600
Brightness/Lumens	600	600	600
Potential Energy Savings ²	—	Potential Energy Savings² \$212.85	

Standard Philips Incandescent BR30	Halogen Energy Advantage BR30	Energy Saver CFL BR30	EnduraLED PAR30
Watts	65W	50W	16W
Rated Average Life ¹	2000	3000	8000
Brightness/Lumens	620	745	650
Potential Energy Savings ²	—	Potential Energy Savings² \$4.95	Potential Energy Savings² \$39.20
Watts	12W	45,000	700
Rated Average Life ¹	45,000	700	700
Brightness/Lumens	700	700	700
Potential Energy Savings ²	—	Potential Energy Savings² \$262.35	

Standard Philips Halogen PAR38	Halogen Energy Advantage IRC PAR38	Energy Saver CFL PAR38	EnduraLED PAR38
Watts	75W	60W	23W
Rated Average Life ¹	3000	4200	8000
Brightness/Lumens	1050	1120	1300
Potential Energy Savings ²	—	Potential Energy Savings² \$6.93	Potential Energy Savings² \$41.60
Watts	17W	45,000	880
Rated Average Life ¹	45,000	880	880
Brightness/Lumens	880	880	880
Potential Energy Savings ²	—	Potential Energy Savings² \$287.10	

1) Rated average life (RAL) is the length of operation (in hours) at which point an average of 50% of the lamps will still be operational and 50% will not.
 2) Rated average life (RAL) of LED lamps is based on engineering testing and probability analysis.
 2) Based on (wattage saved) multiplied by (upgrade product rated average life) divided by (1000 x kWh rate (¢11)) = Amount saved in dollars.
 Your actual savings may vary depending on the energy costs in your geographic location.



Replaced 1000watt MH with 309watt LED

- One for One Replacement
- Utilized existing Poles
- Improved Lighting
- Almost a 70% energy savings.
- Led Fixtures will last 5 times as long as the existing Metal Halides.

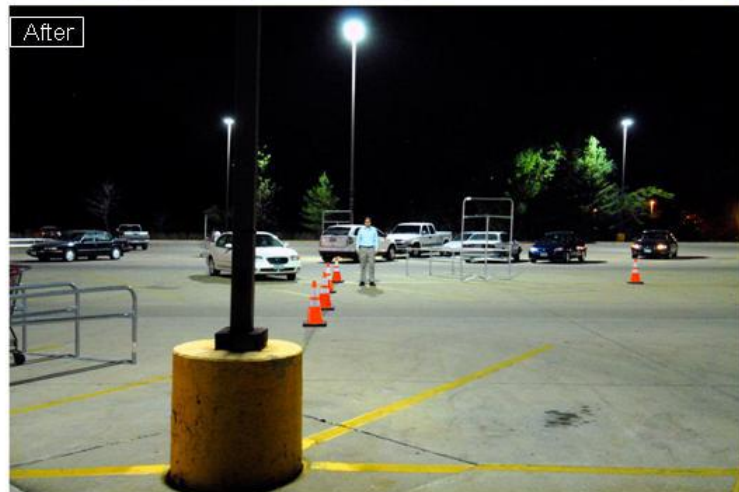

Energy Codes

- The State of Iowa is governed by two energy codes:
 - ASHRAE 90.1-2007, Section 9
 - IECC 2009
- Both are more or less equal and set maximum power densities for every type of Building and/or particular Space
- Both went into effect on January 1, 2010

9.1.2 Lighting Alterations

- The replacement of lighting systems in any building space shall comply with the LPD requirements of Section 9 applicable to that space. New lighting systems shall comply with the applicable LPD requirements of Section 9. Any new control devices as a direct replacement of existing control devices shall comply with the specific requirements of Section 9.4.1.2(b).

9.4.1.2 Space Control

- Each space enclosed by ceiling height partitions shall have at least one control device independently control the general lighting within the space. Each manual device shall be readily accessible And located so the occupants can see the controlled lighting.
- A control device shall be installed that automatically turns lighting off within 30 minutes of all occupants leaving a space, except spaces with multi-scene control, in conference/meeting rooms, employee lunch and break rooms.
- For all other spaces, each control device shall be activated either manually by an occupant automatically by sensing an occupant. Each control device shall control a maximum of 2500 ft² area for a space 10,000 ft² or less and a maximum of 10,000 ft² area for a space greater than 10,000 ft² and be capable of overriding any time-of-day scheduled shutoff control for no more than four hours.

9.1.2 Lighting Alterations

- **Exception:** *Alterations that replace less than 50% of the luminaires in a space need not comply with these requirements provided that such alterations do not increase the installed interior lighting power.*

9.1.3 Installed Interior Lighting Power

- The installed interior lighting power shall include all power used by the luminaires, including lamps, ballasts, transformers, and control devices except as specifically exempted in Section 9.2.2.3.
- **Exception:** If two or more independently operating lighting systems in a space are capable of being controlled to prevent simultaneous user operation, the installed interior lighting power shall be based solely on the lighting system with the highest wattage.

9.2.2.3 Exceptions for Commercial Lighting

- a. Display or accent lighting that is an essential element for the function performed in galleries, museums, and monuments.
- d. Lighting integral to both open and glass-enclosed refrigerator and freezer cases.
- e. Lighting integral to food warming and food preparation *equipment*.
- g. Lighting in spaces specifically designed for use by occupants with special lighting needs including visual impairment and other medical and age-related issues.
- h. Lighting in *retail display windows*, provided the *display* area is enclosed by ceiling-height partitions.
- i. Lighting in interior spaces that have been specifically designated as a registered interior *historic landmark*.
- j. Lighting that is an integral part of advertising or directional signage.
- k. Exit signs.
- l. Lighting that is for sale or lighting educational demonstration systems.
- m. Lighting for theatrical purposes, including performance, stage, and film and video production.
- n. Lighting for television broadcasting in sporting activity areas.
- o. Casino gaming areas.
- p. Furniture-mounted supplemental task lighting that is controlled by automatic shutoff and complies with Section 9.4.1.4(d).

9.1.4 Luminaire Wattage

- Luminaire wattage incorporated into the installed interior lighting power shall be determined in accordance with the following criteria:
- (a). The wattage of incandescent or tungsten-halogen luminaires with medium screw base sockets and not containing permanently installed ballasts shall be the maximum labeled wattage of the luminaire.
- (b). The wattage of luminaires with permanently installed or remote ballasts or transformers shall be the operating input wattage of the maximum lamp/auxiliary combination based on values from the auxiliary manufacturers' literature or recognized testing laboratories or shall be the maximum labeled wattage of the luminaire.

9.1.4 Luminaire Wattage (con't)

- c. For line-voltage lighting track and plug-in busway, designed to allow the addition and/or relocation of luminaires without altering the wiring of the system, the wattage shall be:
 - 1. the specified wattage of the luminaires included in the system with a minimum of 30 W/linear ft or
 - 2. the wattage limit of the system's circuit breaker or
 - 3. the wattage limit of other permanent current-limiting device(s) on the system.
- d. The wattage of low-voltage lighting track, cable conductor, rail conductor, and other flexible lighting systems that allow the addition and/or relocation of luminaires without altering the wiring of the system shall be the specified wattage of the transformer supplying the system.
- e. The wattage of all other miscellaneous lighting equipment shall be the specified wattage of the lighting equipment.

9.4 Mandatory Provisions

9.4.1 Lighting Control

9.4.1.1 Automatic Lighting Shutoff

- Interior lighting in buildings larger than 5000 ft² shall be controlled with an automatic control device to shut off building lighting in all spaces. This automatic control device shall function on either
- (a). a scheduled basis using a time-of-day operated control device that turns lighting off at specific programmed times—an independent program schedule shall be provided for areas of no more than 25,000 ft² but not more than one floor—or
- (b). an occupant sensor that shall turn lighting off within 30 minutes of an occupant leaving a space or
- (c). a signal from another control or alarm system that indicates the area is unoccupied.

9.4.1.1 Automatic Lighting Shutoff - Exceptions

- (a). Lighting intended for 24-hour operation.
- (b). an occupant sensor that shall turn lighting off within 30 minutes of an occupant leaving a space or
- (c). Lighting in spaces where an automatic shutoff would endanger the safety or security of the room or building occupant(s).

9.4.2 Tandem Wiring

- Luminaires designed for use with one or three linear fluorescent lamps greater than 30 W each shall use two-lamp tandem-wired ballasts in place of single lamp ballasts when two or more luminaires are in the same space and on the same control device.

9.4.2 Tandem Wiring (con't)

- **Exceptions:**
 - a. Recessed luminaires more than 10 ft apart measured center to center.
 - b. Surface-mounted or pendant luminaires that are not continuous.
 - c. Luminaires using single-lamp high-frequency electronic ballasts.
 - d. Luminaires using three-lamp high-frequency electronic or three-lamp electromagnetic ballasts.
 - e. Luminaires on emergency circuits.
 - f. Luminaires with no available pair.

TABLE 9.5.1 Lighting Power Densities Using the Building Area Method

- Dormitory – 1.0W
- Gymnasium – 1.1W
- Library – 1.3W
- Museum – 1.1W
- Performing Arts Theatre – 1.6W
- School/University – 1.2W
- Workshop – 1.4W

TABLE 9.6.1 Lighting Power Densities Using the Space-by-Space Method

- Classroom/Lecture/Training – 1.3W
- Food Preparation – 1.2W
- Locker Rooms – 0.6W
- Stairs – Active – 0.6W
- Dormitory-Living Quarters – 1.1W
- Sports Arena-Court Sports – 2.3W

Lighting Controls

Education Spaces

Why look at lighting controls?

- Simple Math:
- Lighting uses 31% of Total Electricity in Education.
- 40% savings x 31% = 12% overall savings
- Source: HBA & Energy Information Administration

Simple Fact:

- The best way to save energy is turn it off when it is no longer needed.

Education Opportunities



Previous/Current Method of Control



Review the Basic Types of Occupancy Sensors



Passive Infra Red (PIR) – Relies on “line-of-sight” coverage to detect occupancy by sensing the difference in heat emitted by humans in motion from that of the background space.



Ultrasonic – Utilizes the Doppler principle to detect occupancy through emitting ultrasonic sound waves throughout a space.



Dual Technology - Employs both PIR and ultrasonic technologies. DT sensors will activate lights when both sensing technologies detect occupancy, but will continue to hold lighting on as long as one technology detects continued occupancy.

Daylight Harvesting Basics

- It makes sense:

Timing is Right for Daylight Harvesting

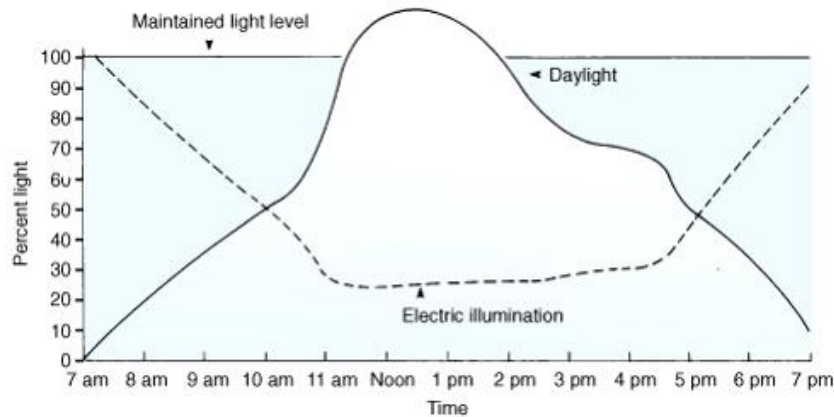

Dimming electric light using a photo sensor to maintain a consistent lighting level

Two Types of Daylight Harvesting

- Open Loop

- Closed Loop

What is open loop control?

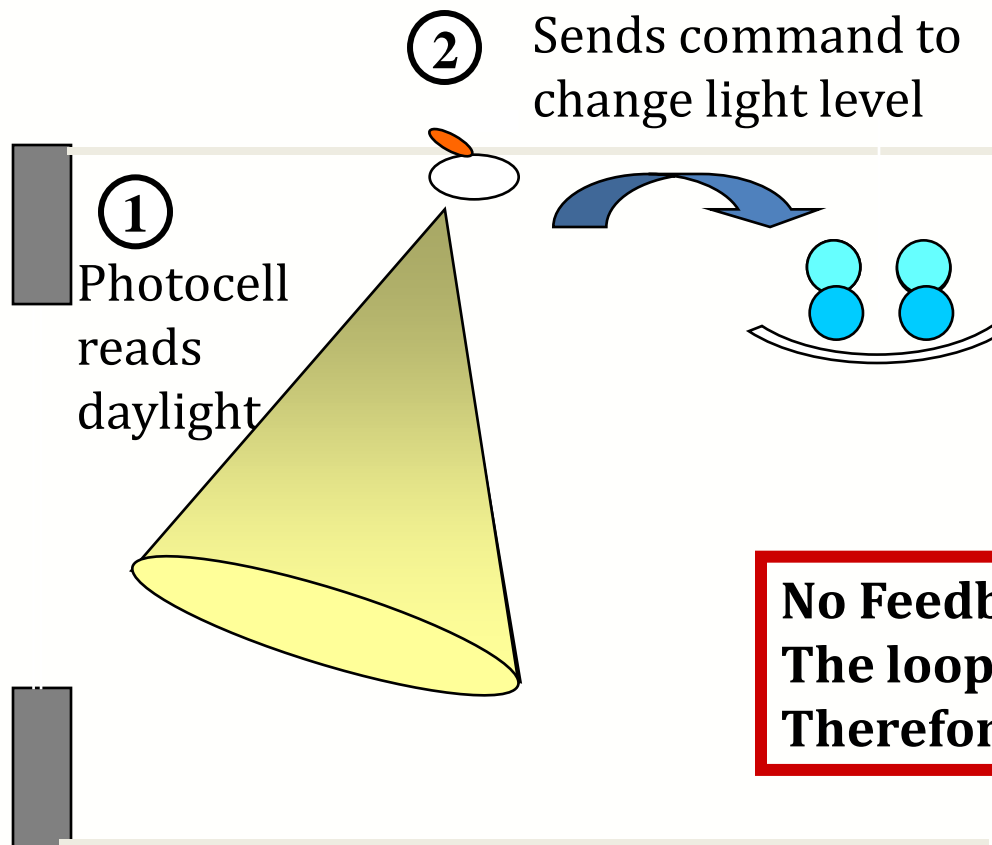

**No Feedback.
The loop is not closed.
Therefore, an “open loop”**

What is closed loop control?

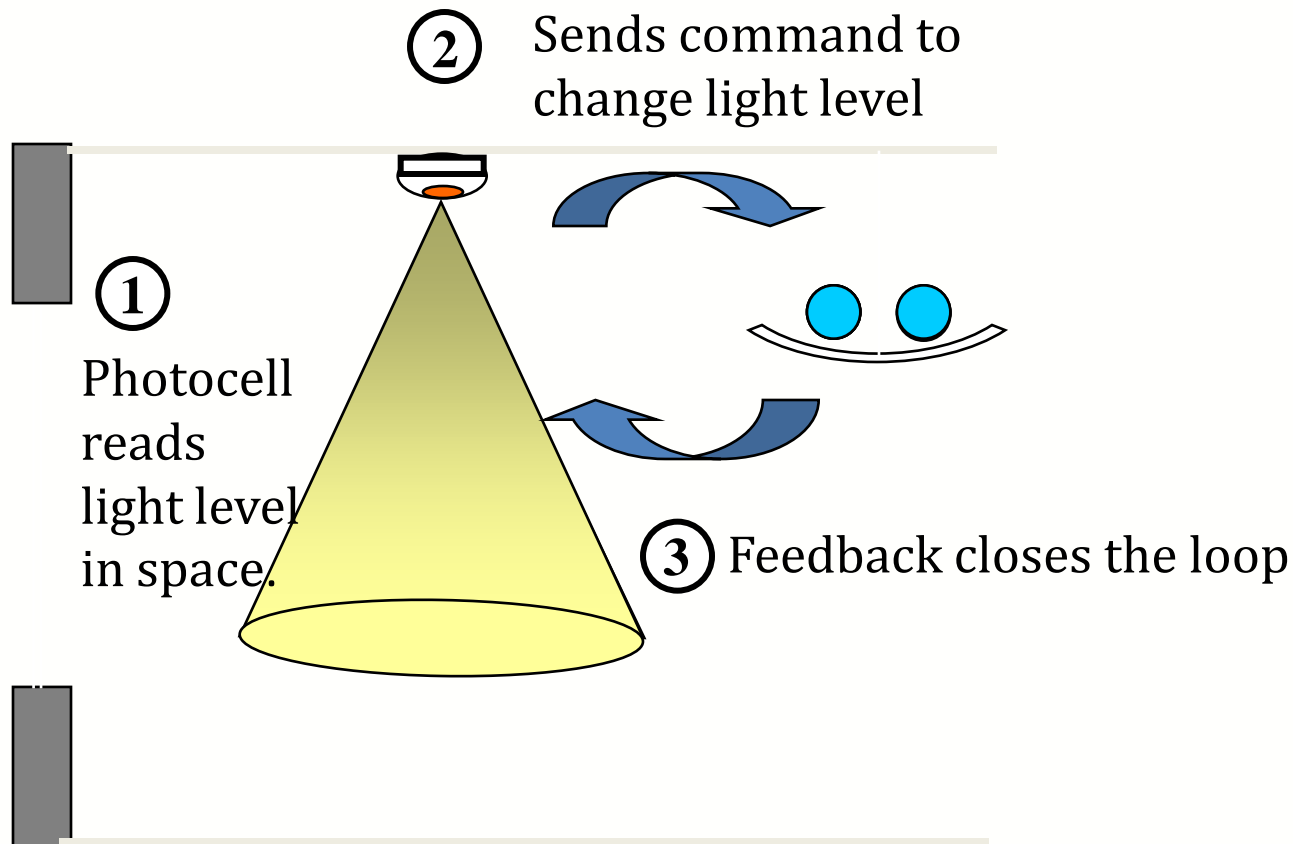

Recent Advancements

- Hard Wired:
- Cat 5e terminations

- Wireless:
- With or without neutral wire

Wiring Diagram: The Present!

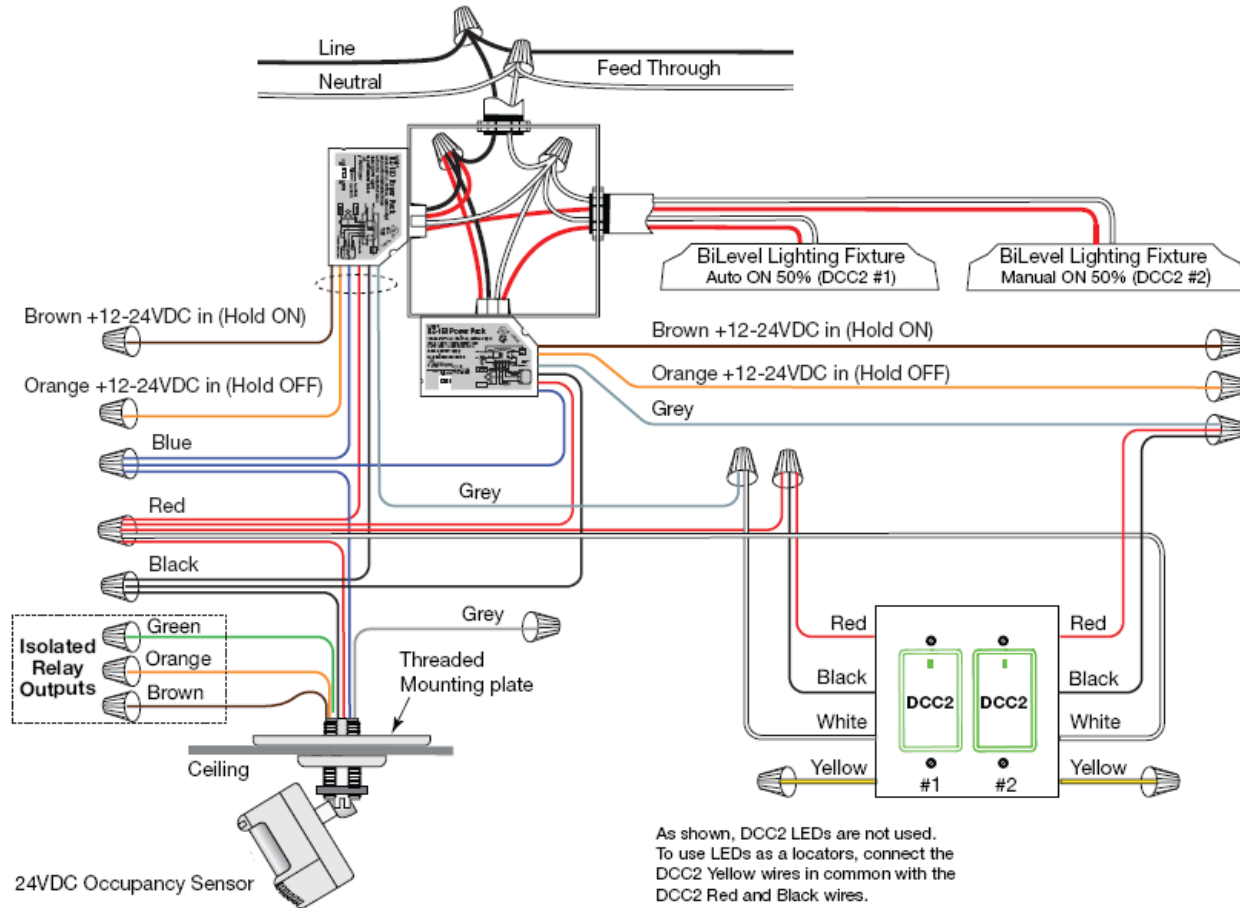

Connections via Cat5e cable

- Example:



Two Load Application

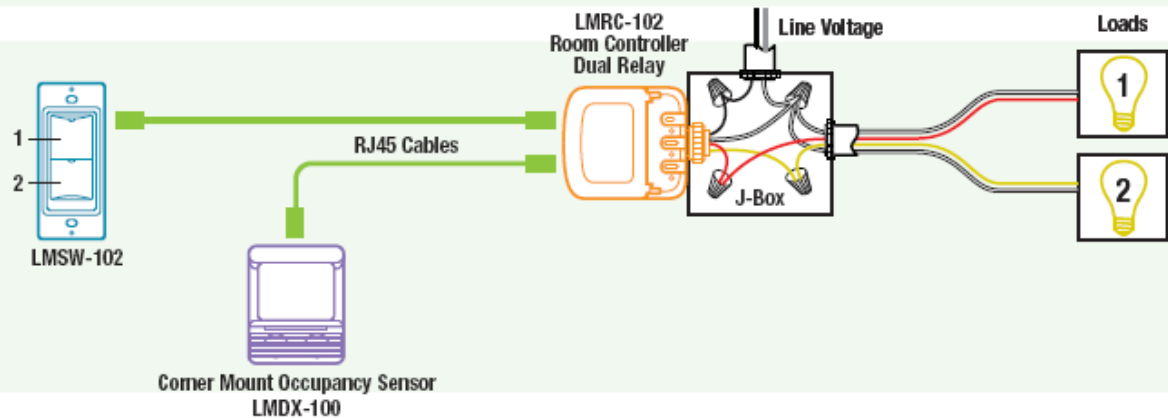

Wireless Connections

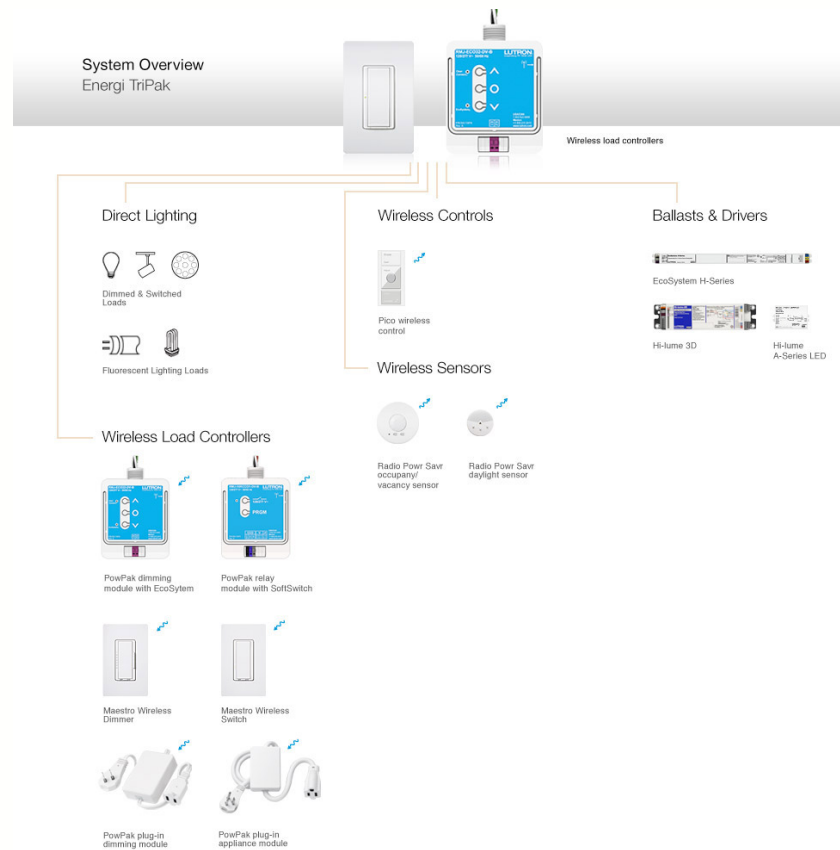

Recent Advancements Continued

- Fully integrated with building control systems:
- Ex. Johnson Controls

- Monitoring Usage and Lighting Controls via internet by remote hardware and software devices.

Combination of Control Types

- Utilizes:
 - Occupancy Sensors-wired or unwired
 - Manual Override
 - Daylight Harvesting
 - Dimming
 - And, yes wall switches!

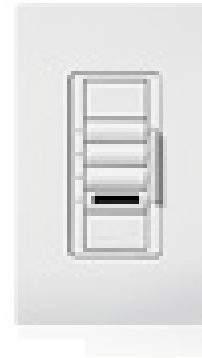

Questions to ask when designing a system:

- Number of circuits to be controlled?
- Circuit ampacity?
- Circuit voltage?
- Method of control:
 - Occupancy Sensor
 - Daylight Harvesting
 - Switches

Questions to Ask (continued)

- Does daylight harvesting make sense?
- Is bi-level switching required?

Questions?

- Joe Bryan, LC
- Lighting Specialist EBU
- Van Meter Inc.

- Phone 563-336-3261
- Email jbryan@vanmeterinc.com