

Storing Up Efficiency with Innovative Warehouse Lighting



Joe is a native Georgian, employed by Van Meter since 2006. He is responsible for lighting and control design for Eastern Iowa including Davenport, Muscatine, Burlington, and Keokuk. Joe is also technical resource for customers and offers onsite training and product/technology updates. Member of the IESNA since 2007 with 19 years total experience in the Electrical Distribution field and 12 years experience in lighting.



Todd has been with Van Meter since March of 2003 as the Lighting Specialist for West Central Iowa. He works closely with electrical contractors, architects, and specifiers on design/build projects, as well as lighting energy audits. Prior to coming to Van Meter, he worked for CED-Des Moines as an Inside Salesperson and before that worked for a high-voltage electrical equipment manufacturers representative agency in Kansas and Missouri calling on REC's, Municipalities, and investor owned Utilities. Todd is a graduate of the University of Iowa with a B.A. in Communications.



Bob Workman, a Lighting Specialist for Van Meter Inc., has been in the industry for more than four years. His responsibilities include lighting design, sales and education and lighting and energy audits. He gives consultation to commercial, institutional, industrial and contractor businesses and works to support his fellow Van Meter sales people covering East Central Iowa including Cedar Rapids, Iowa City, Waterloo, Dubuque and Mason City.

Sustainability

- Sustainability is defined as meeting the needs of the present generation without compromising the ability of future generations to meet their own needs.

How Does Lighting Impact the Environment

- Green House Gas Emissions from Electricity consumption.
- Toxicity from Mercury and other Hazardous material.
- Material Consumption and Disposal.

Sustainable Lighting

How do we reduce the environmental impact?

- More Energy Efficient Lighting Systems
- Lower or no Mercury.
- Long Lamp Life/Recycling.

Which Technologies are Sustainable?

- Obsolete/Not Sustainable
 - Probe Start Metal Halide
 - T12 Magnetic Fluorescent
 - Incandescent/Halogen
- Not Obsolete/Better
 - -Standard T8/T5 Fluorescent- Standard Fixtures
 - Pulse Start Metal Halide
 - High Pressure Sodium
 - Higher Efficiency Halogen
 - Screw in CFL's

Which Technologies are Sustainable?

- Sustainable Lighting

- High Efficiency/Long Life/Low Mercury T8 and T5 in High Efficiency Fixtures.
- High Efficiency HID
- Induction Lighting
- High Quality LED
- Lighting Controls

Light Source	Lumens/Watt	Lamp Life (hrs)	Mercury Content
Probe Start Metal Halide	40-70	10,000-20,000	20mg+
T12 Fluorescent	50-70	20,000	20mg+
Incandescent and Halogen	15-40	1,000-5,000	0
Pulse Start Metal Halide	60-90	20,000	20mg+
Standard T8/T5	70-100	30,000-35,000	1.7mg(philips) 3+(the rest)
High Efficiency Halogen	30-50	2500-5000	0
Compact Fluorescent	50-80	8,000-20,000	2mg-15mg
High Efficiency Long Life T8/T5	90-120	Up to 46,000	1.7mg(philips) 3+(the rest)
High Efficiency Metal Halide	90-120	Up to 30,000	20mg+
Induction Lighting	80-100	100,000	5mg-10mg
LED	50-90	25,000-100,000	0

What is Induction Lighting

An **Induction Lamp** is similar to a fluorescent lamp in that mercury in a gas fill inside the bulb is excited, emitting UV radiation that in turn is converted into visible white light by the phosphor coating on the bulb. Fluorescent lamps, however, use electrodes inside the bulb to strike the arc and initiate the flow of current – each the arc is struck, the electrodes degrade a little, eventually causing the lamp to flicker and then fail.

Induction Lamps differ in that they do not use internal electrodes, but use a high-frequency generator with a power coupler. The generator produces a radio frequency magnetic field to excite the gas fill.



Lamp Life & Lumen Maintenance

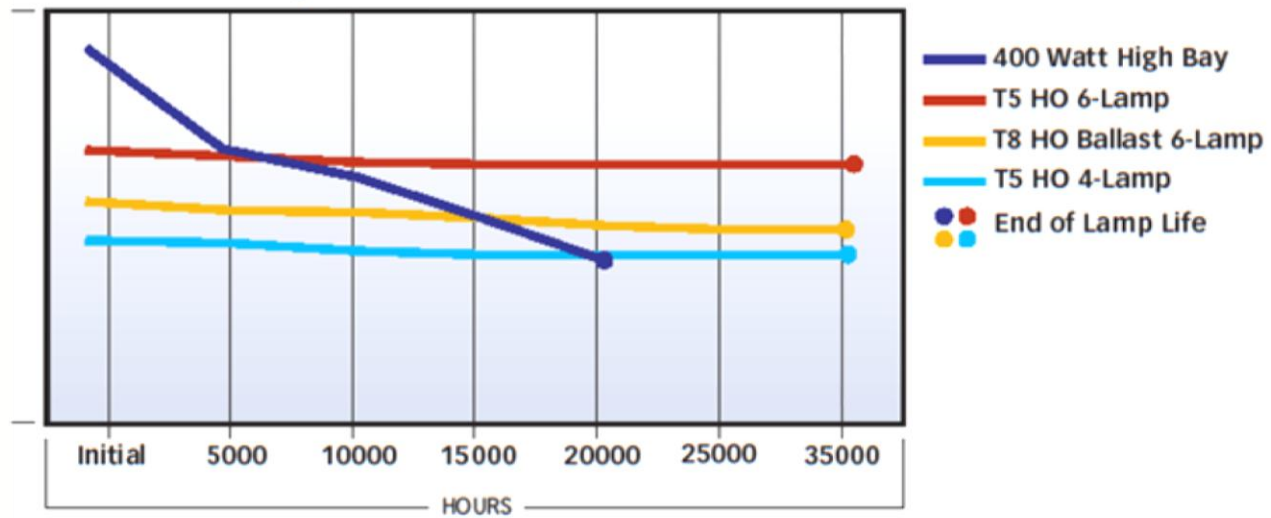

Thermal Performance and Light Output

Unlike HID lamps, T5 and T8 lamps reach optimal light output in specific temperature ranges. In partially or unconditioned spaces, temperatures from floor to ceiling can increase by over 20° in summer months.

Partially Conditioned Spaces

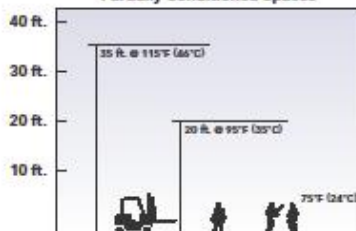

Annual Temperature Days Over 85°F (29°C)



Bare Lamp Output in Ambient Temperatures

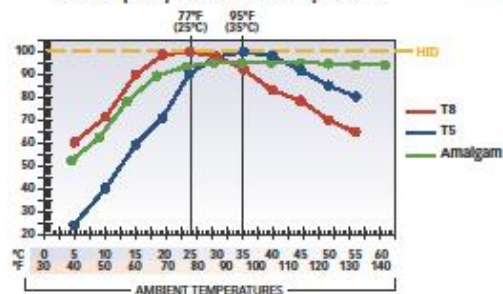

Thermally advanced Cooper Lighting industrial products optimize light output of T5HO and T8 lamps for their designed temperature ranges. Choose lamp types that optimize light output for your ambient environment and consider the use of T5HO Amalgam lamps for higher performance over wider temperature ranges.



The Metalux Arctic Bay retains and manages heat allowing it to provide over 70% of light output in freezer applications down to -20°F (-29°C).



Metalux's F-Bay series can be operated in environments up to 149°F (65°C) in open upright configurations.

Thermal Optimization

To optimize luminaire performance, HBI series offers a variety of lamp and shielding options. Use the Thermal Optimization chart to determine the options that are appropriate for the ambient environments in which they will be installed.

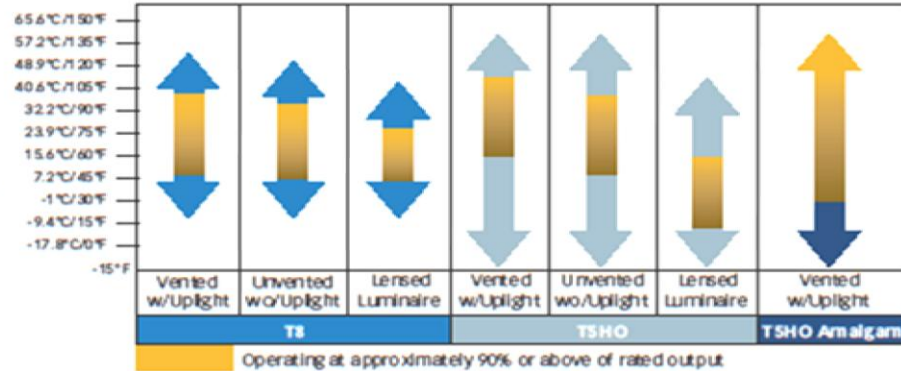

System Performance

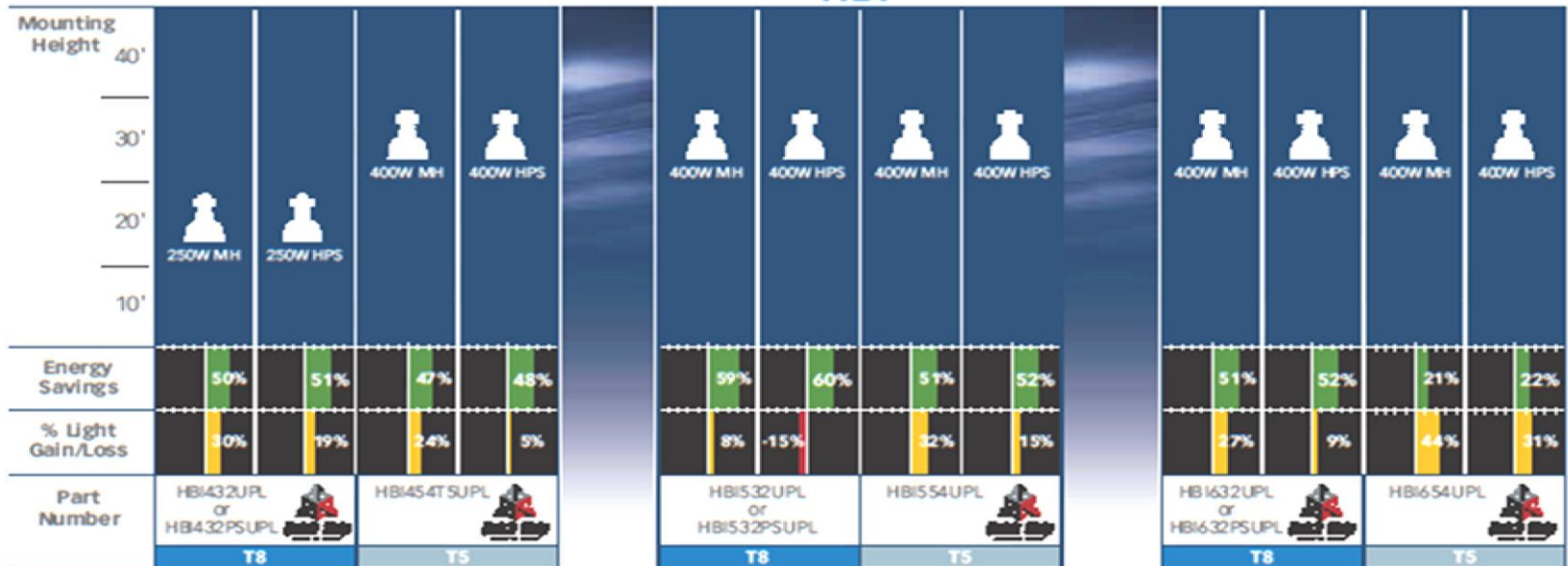

LED and Induction

- Both have 70% Lumen Maintenance at rated end of Life.
- LED Likes Cold but does not Like Heat (Check Manufacturer Rating and Test Results.)
- Induction Works Well in all Temperature ratings (Check Temperature rating of Electronic Driver.

LED

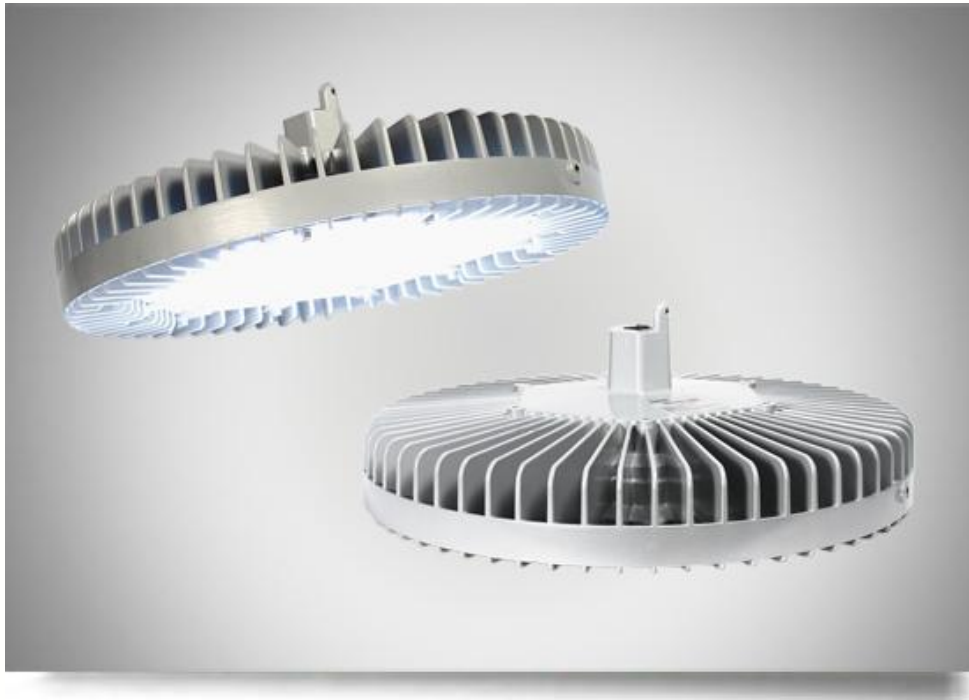

Induction



Energy Codes

- The State of Iowa is governed by two energy codes:
- ASHRAE 90.1-2007, Section 9
- IECC 2009
- Both are more or less equal and set maximum power densities for every type of Building and/or particular Space
- Both went into effect on January 1, 2010

9.1.2 Lighting Alterations

The replacement of lighting systems in any building space shall comply with the LPD requirements of Section 9 applicable to that space. New lighting systems shall comply with the applicable LPD requirements of Section 9. Any new control devices as a direct replacement of existing control devices shall comply with the specific requirements of Section 9.4.1.2(b).

9.4.1.2 Space Control

Each space enclosed by ceiling height partitions shall have at least one *control device independently control the general lighting within the space. Each manual device shall be readily accessible And located so the occupants can see the controlled lighting.*

(b). For all other spaces, each *control device shall be activated* either manually by an occupant automatically by sensing an occupant. Each *control device shall control a maximum of 2500 ft² area fo a space 10,000 ft² or less and a maximum of 10,000 ft² area for a space greater than 10,000 ft² and be capable of overriding any time-of-day scheduled shutoff control for no more than four hours.*

9.1.2 Lighting Alterations

Exception: *Alterations that replace less than 50% of the *luminaires* in a *space* need not comply with these requirements provided that such *alterations do not* increase the installed interior lighting power.*

9.1.3 Installed Interior Lighting Power

The installed interior lighting power shall include all power used by the luminaires, including lamps, ballasts, transformers, and control devices except as specifically exempted in Section 9.2.2.3.

Exception: If two or more independently operating lighting systems in a space are capable of being controlled to prevent simultaneous user operation, the installed interior lighting power shall be based solely on the lighting system with the highest wattage.

9.2.2.3 Exceptions for Warehouse Lighting

- (b). Lighting that is integral to equipment or instrumentation and is installed by its manufacturer.
- (k). Exit signs (Max of 5W)

9.4 Mandatory Provisions

9.4.1 Lighting Control

9.4.1.1 Automatic Lighting Shutoff

Interior lighting in buildings larger than 5000 ft² shall be controlled with an automatic control device to shut off building lighting in all spaces. This automatic control device shall function on either

- (a). a scheduled basis using a time-of-day operated control device that turns lighting off at specific programmed times—an independent program schedule shall be provided for areas of no more than 25,000 ft² but not more than one floor—or
- (b). an occupant sensor that shall turn lighting off within 30 minutes of an occupant leaving a space or
- (c). a signal from another control or alarm system that indicates the area is unoccupied.

9.4.1.1 Automatic Lighting Shutoff - Exceptions

- (a). Lighting intended for 24-hour operation.
- (c). Lighting in spaces where an automatic shutoff would endanger the safety or security of the room or building occupant(s).

TABLE 9.6.1 Lighting Power Densities Using the Space-by-Space Method

Office-Enclosed – 1.1W

Restrooms – 0.9W

Electrical/Mechanical – 1.5W

Warehouse:

Fine Material Storage – 1.4W

Medium/Bulky Material Storage – 0.9W

Lighting Controls

Warehouse Spaces

Why look at lighting controls?

Simple Math:

Lighting uses 26% of Total Electricity in *Warehouse*
Applications

40% savings x 26% = 10% overall savings

Source: Watt Stopper & Energy Information Administration

Simple Fact:



Warehouses

The best way to save energy is turn it off when it is no longer needed.

Ancient Control Methods



Current Control Methods:

- Individual Control of Light Fixtures
- Group or Control by rows
- Daylight Harvesting

Review the Basic Types of Occupancy Sensors



Passive Infra Red (PIR) – Relies on “line-of-sight” coverage to detect occupancy by sensing the difference in heat emitted by humans in motion from that of the background space.



~~**Ultrasonic** – Utilizes the Doppler principle to detect occupancy through emitting ultrasonic sound waves throughout a space.~~



~~**Dual Technology** – Employs both PIR and ultrasonic technologies. DT sensors will activate lights when both sensing technologies detect occupancy, but will continue to hold lighting on as long as one technology detects continued occupancy.~~

Individual Controls Components:

- Line voltage Passive Infrared Sensor
- Appropriate lens
- Mounting Adapter

Group Controls Components:

- Line voltage or Low voltage Passive Infrared Sensor
- Appropriate Lens
- Mounting Adapter
- Power Pack (if required)

Daylight Harvesting Basics

Skylighting:



Daylight Harvesting Basics

It makes sense:
Timing is Right for Daylight Harvesting

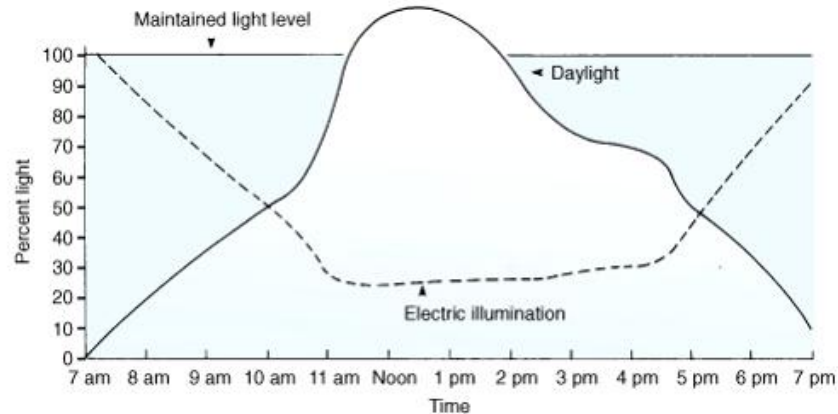

Dimming electric light using a photo sensor to maintain a consistent lighting level

Two types of Daylight Harvesting

Open Loop

Closed Loop

What is open loop control?

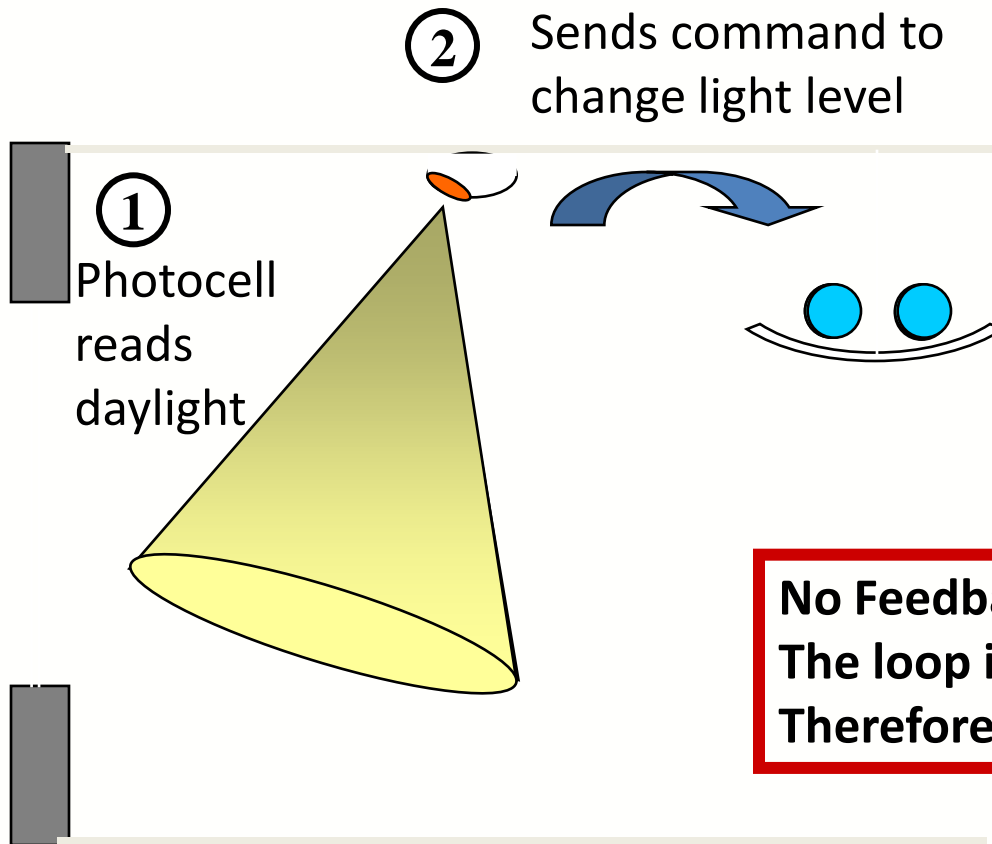

What is closed loop control?

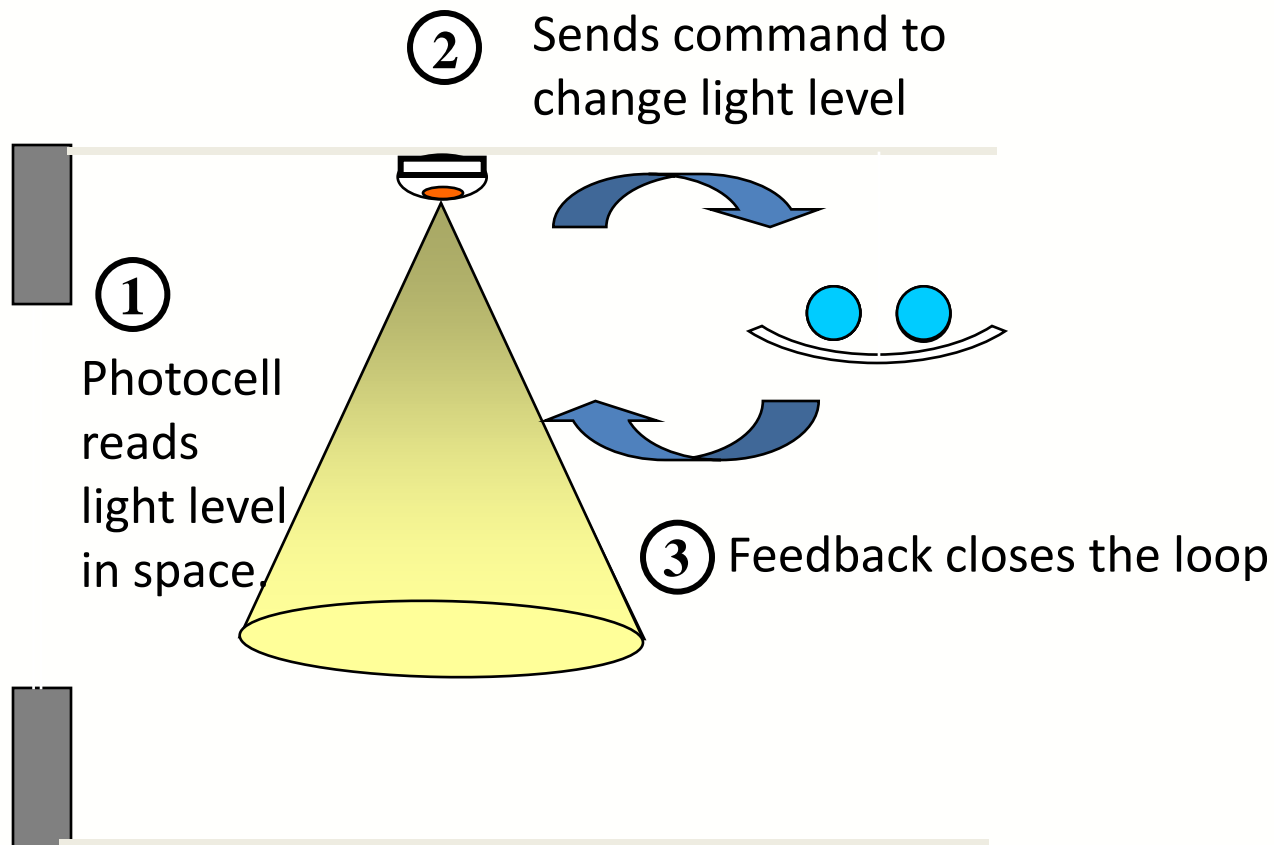

Recent Advancements

Hard Wired:
Cat 5e terminations

Wireless:
With or without neutral wire

wiring diagram: the Present!

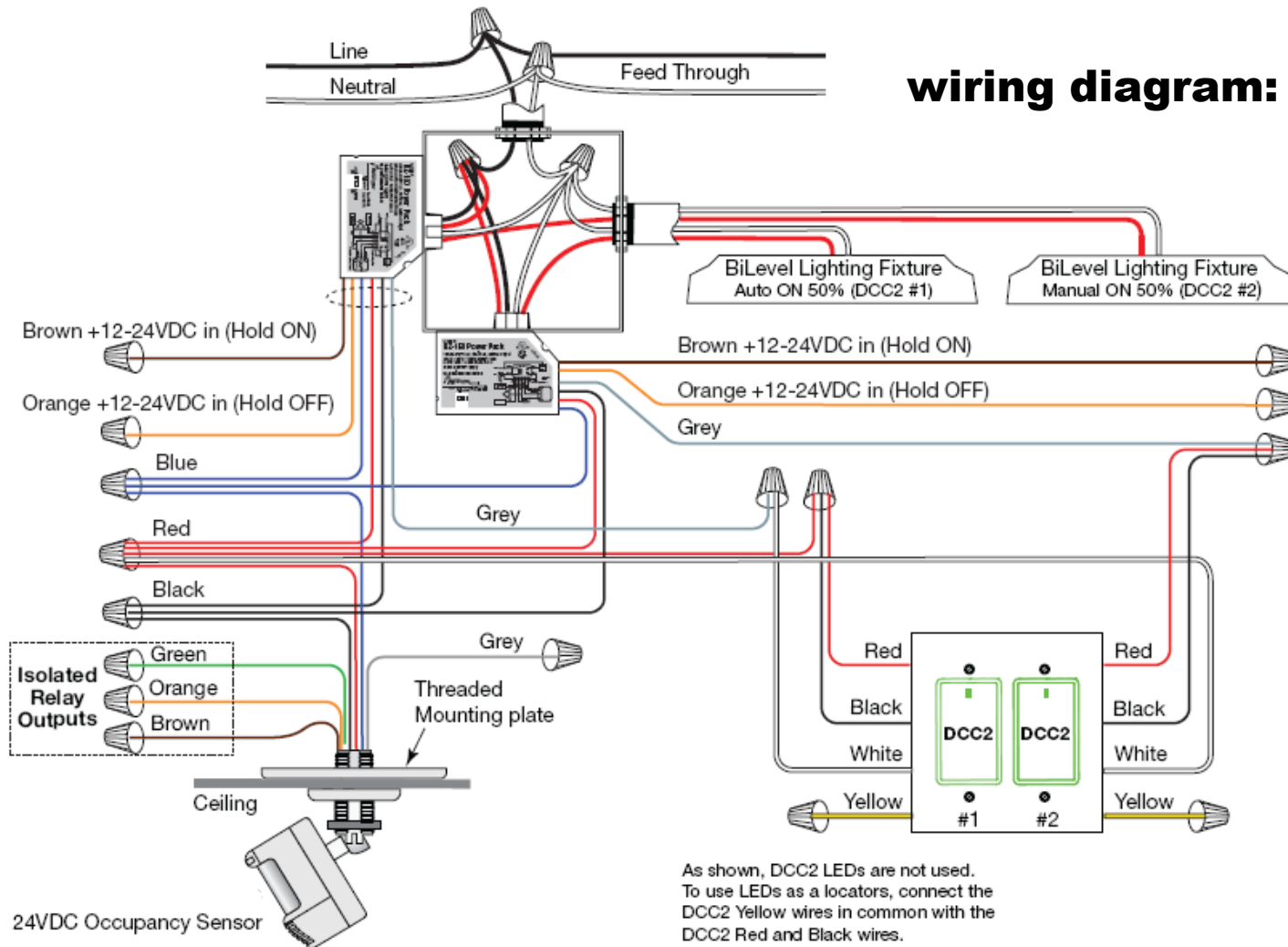

As shown, DCC2 LEDs are not used.
 To use LEDs as locators, connect the
 DCC2 Yellow wires in common with the
 DCC2 Red and Black wires.

Connections via Cat5e cable

Example:



Two Load Application

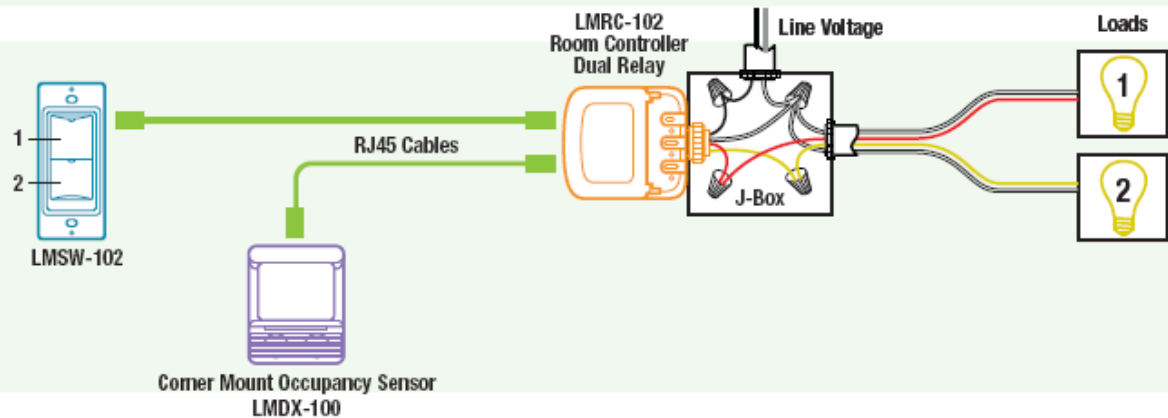

Wireless Connections

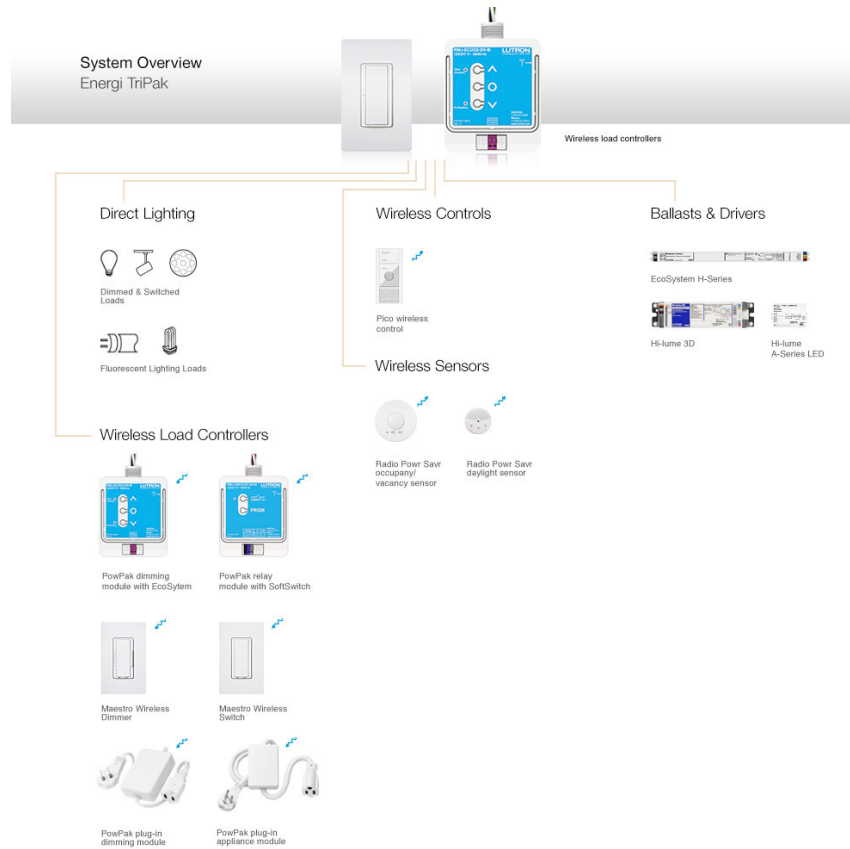

Recent Advancements Continued

Fully integrated with building control systems:

Ex. Johnson Controls

Monitoring Usage and Lighting Controls via internet
by remote hardware and software devices

Questions to ask when designing a system:

- Number of circuits to be controlled?
- Circuit ampacity?
- Circuit voltage?
- Method of control:
- Occupancy Sensor-individual or group
- Daylight Harvesting
- Scheduling

Questions to Ask (continued)

- Does daylight harvesting make sense?
- Is bi-level switching required?
- Individual or group controls?

Questions?

Joe Bryan, LC
Lighting Specialist EBU
Van Meter Inc.

Phone 563-336-3261
Email jbryan@vanmeterinc.com